

QPD CW 3PE2,5 2X9-14 BK - Conductor connectors



1582539

<https://www.phoenixcontact.com/us/products/1582539>

Please be informed that the data shown in this PDF document is generated from our online catalog. Please find the complete data in the user documentation. Our general terms of use for downloads are valid.



Cable connector panel feed-through, two-sided with QPD nut, black, 3+ PE pos., 1.0 mm² ... 2.5 mm²/630 V/20 A, for cable diameters of 9 mm ... 14 mm.

Your advantages

- Innovative and time saving - QUICKON fast connection for time saving of up to 80 % for on-site connection
- Robust throughout: housing with IP68/IP69K and IK07 protection for a wide range of applications
- Safer connection with mechanical coding to protect against mismatching, and touch-proof protection in accordance with DIN EN 0105
- Easy and safe - with the cable connector, you can repair or extend cables quickly, in combination with the connector as well as the coupling connection

Commercial data

Item number	1582539
Packing unit	1 pc
Minimum order quantity	1 pc
Note	Made to order (non-returnable)
Sales key	BF50
Product key	BF6CBB
Catalog page	Page 384 (C-4-2013)
GTIN	4046356552479
Weight per piece (including packing)	73.3 g
Weight per piece (excluding packing)	73.3 g
Customs tariff number	85366990
Country of origin	DE

1582539

<https://www.phoenixcontact.com/us/products/1582539>

Technical data

Product properties

Type	QPD 4x2,5
Product type	Panel feed-through
Product family	QPD
Number of positions	4
Connection profile	3+PE
Position marking	1, 2, 3, PE
Number of connections	10
Number of connections per position	1
Coding	Coding profile

Insulation characteristics

Overvoltage category	III
Degree of pollution	3

Connection data

Connection technology

Connection technology	QUICKON connection
Connection system, internal	IDC connection
Frequency of connections between conductors of the same cross section	max. 10

Conductor connection

Conductor cross section flexibel	1 mm ² ... 2.5 mm ²
Conductor cross section solid	1 mm ² ... 2.5 mm ²
Connection cross section AWG	16 ... 14
Tightening torque Union nut	5 Nm
Tightening torque Locking nut	5 Nm
Wrench size Union nut	22 mm
Wrench size Locking nut	27 mm

Dimensions

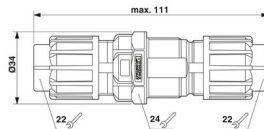
Dimensional drawing	
Width	34 mm
Height	34 mm
Length	111 mm
Diameter	34 mm

1582539

<https://www.phoenixcontact.com/us/products/1582539>

Electrical properties

Rated surge voltage (II/2)	8 kV
Rated surge voltage (III/2)	8 kV
Rated surge voltage (III/3)	6 kV
Rated current	20 A
Contact resistance	< 3 mΩ
rated voltage (II/2)	1000 V
rated voltage (III/2)	1000 V
Rated voltage (III/3)	690 V
Nominal voltage U_N	690 V
Nominal current I_N	20 A

Mechanical properties

Mechanical data

Insertion/withdrawal cycles	max. 50
-----------------------------	---------

Material specifications

Material	PA
	Cu
	Silver-plated
Flammability rating according to UL 94	V0
Material wire insulation	PVC / PE / rubber / TPE

Cable/line

Structure of individual litz in acc. with VDE 0295 / smallest wire diameter	VDE 0295 class 1 to 6/min. 0.15 mm
External cable diameter ()	6 mm ... 10 mm (Order Quickon nuts or Quickon connectors separately)
Wire diameter including insulation	2 mm ... 3.8 mm
Position marking	1, 2, 3, PE
Material wire insulation	PVC / PE / rubber / TPE
Halogen-free	no

Mounting

Connection method	QUICKON fast connection
-------------------	-------------------------

Environmental and real-life conditions

Ambient conditions

Degree of protection	IP66
	IP68 (2 m / 24 h)
	IP69K
Ambient temperature (operation)	-40 °C ... 100 °C
Temperature when conductor connected	-5 °C ... 50 °C

QPD CW 3PE2,5 2X9-14 BK - Conductor connectors



1582539

<https://www.phoenixcontact.com/us/products/1582539>

Ambient temperature (storage/transport)

-40 °C ... 100 °C

QPD CW 3PE2,5 2X9-14 BK - Conductor connectors



1582539

<https://www.phoenixcontact.com/us/products/1582539>

Drawings

Dimensional drawing

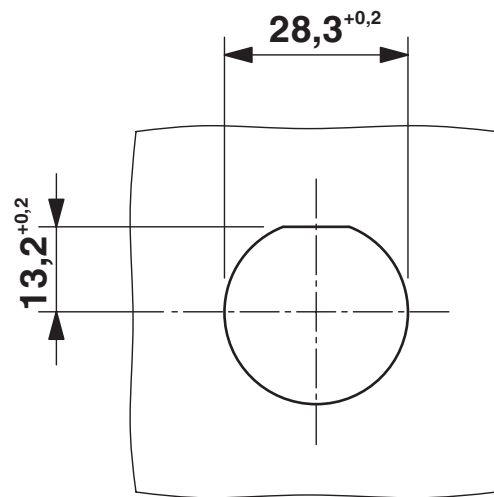

Panel cutout

Dimensional drawing

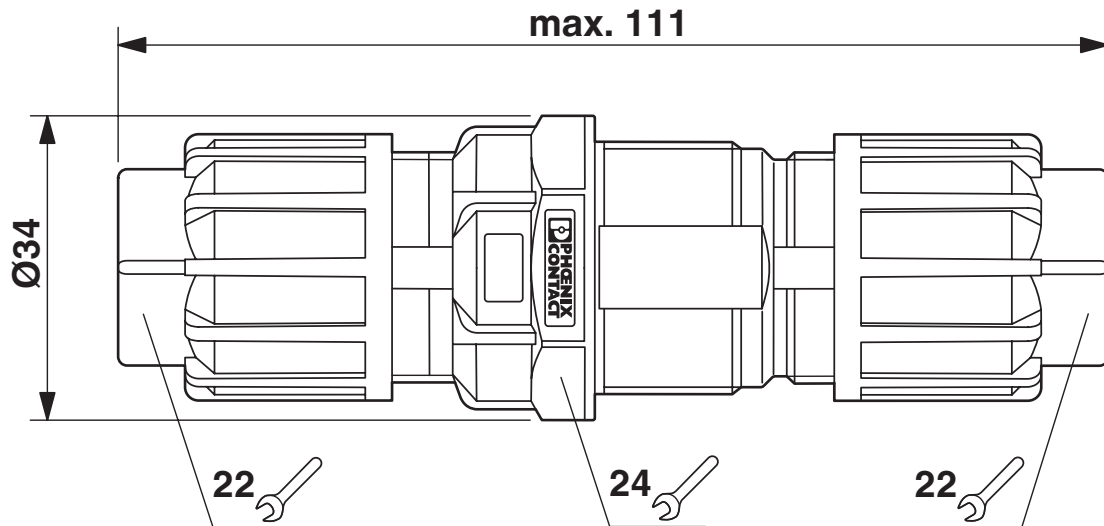

Dimensional drawing

QPD CW 3PE2,5 2X9-14 BK - Conductor connectors



1582539

<https://www.phoenixcontact.com/us/products/1582539>

Classifications

ECLASS

ECLASS-11.0	27440605
ECLASS-13.0	27440605

UNSPSC

UNSPSC 21.0	39121402
-------------	----------

QPD CW 3PE2,5 2X9-14 BK - Conductor connectors



1582539

<https://www.phoenixcontact.com/us/products/1582539>

Environmental product compliance

China RoHS	Environmentally friendly use period: unlimited = EFUP-e
	No hazardous substances above threshold values

QPD CW 3PE2,5 2X9-14 BK - Conductor connectors



1582539

<https://www.phoenixcontact.com/us/products/1582539>

Accessories

GPE 13X 9 WH - Engraving material

0806932

<https://www.phoenixcontact.com/us/products/0806932>

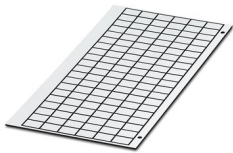

Engraving material, Sheet, white, unlabeled, can be labeled with: PLOTMARK, ENGRAVING UNIT, CMS-P1-PLOTTER, P1 ENGRAVING UNIT, mounting type: adhesive, lettering field size: 13 x 9 mm, Number of individual labels: 120

QPD QSK 2,5 FS - Protective cap

1582488

<https://www.phoenixcontact.com/us/products/1582488>



Plastic protective cap, for QPD-QUICKON connectors, green, with holding band, IP68

QPD CW 3PE2,5 2X9-14 BK - Conductor connectors



1582539

<https://www.phoenixcontact.com/us/products/1582539>

CP-QPD - Coding profile

1582459

<https://www.phoenixcontact.com/us/products/1582459>



Coding profile red, for pushing into the QUICKON dome and connector, can be positioned in 90° steps.

SEALING PLUG 14X22 RD - Closing cap

1400270

<https://www.phoenixcontact.com/us/products/1400270>



Closing cap, for threads pluggable, color: red

QPD CW 3PE2,5 2X9-14 BK - Conductor connectors



1582539

<https://www.phoenixcontact.com/us/products/1582539>

QPD P 3PE2,5 6-10 BK - Connector

1582202

<https://www.phoenixcontact.com/us/products/1582202>



Connector, QUICKON connection, number of positions: 3+PE, 690 V, 20 A, black, external cable diameter: 6 mm ... 10 mm

QPD P 3PE2,5 9-14 BK - Connector

1582205

<https://www.phoenixcontact.com/us/products/1582205>



Connector, QUICKON connection, number of positions: 3+PE, 690 V, 20 A, black, external cable diameter: 9 mm ... 14 mm

1582539

<https://www.phoenixcontact.com/us/products/1582539>

KV-DI-PG16-1XASI - Seal

1582462

<https://www.phoenixcontact.com/us/products/1582462>



Seal for one AS-i line, 17.2 x 9 mm, from NBR, black, for IP65/67 degree of protection

KV-DI-PG16-2XASI - Seal

1582464

<https://www.phoenixcontact.com/us/products/1582464>



Seal for two AS-i lines, 17.2 x 9 mm, from NBR, black, for IP65/67 degree of protection

QPD CW 3PE2,5 2X9-14 BK - Conductor connectors

1582539

<https://www.phoenixcontact.com/us/products/1582539>



QPD N 2,5 6-10 BK - Nut

1582226

<https://www.phoenixcontact.com/us/products/1582226>



Nut, QUICKON connection, number of positions: 3+PE, 690 V, 20 A, black, external cable diameter: 6 mm ... 10 mm

QSS 22 - Socket wrench

1670206

<https://www.phoenixcontact.com/us/products/1670206>



Allen wrench, for loosening and fastening the QUICKON union nut, WAF 22 mm

Phoenix Contact 2023 © - all rights reserved
<https://www.phoenixcontact.com>

Phoenix Contact USA
586 Fulling Mill Road
Middletown, PA 17057, United States
(+717) 944-1300
info@phoenixcon.com